

KYLIA

COH-24 & COH 28

- Coherent optical architectures
- Coherent mechanical packages and labelling
- Phase shift stability in temperature
- Phase shift stability over wavelenght range
- Coherent receiver characterization methods

Theoretical Diagram

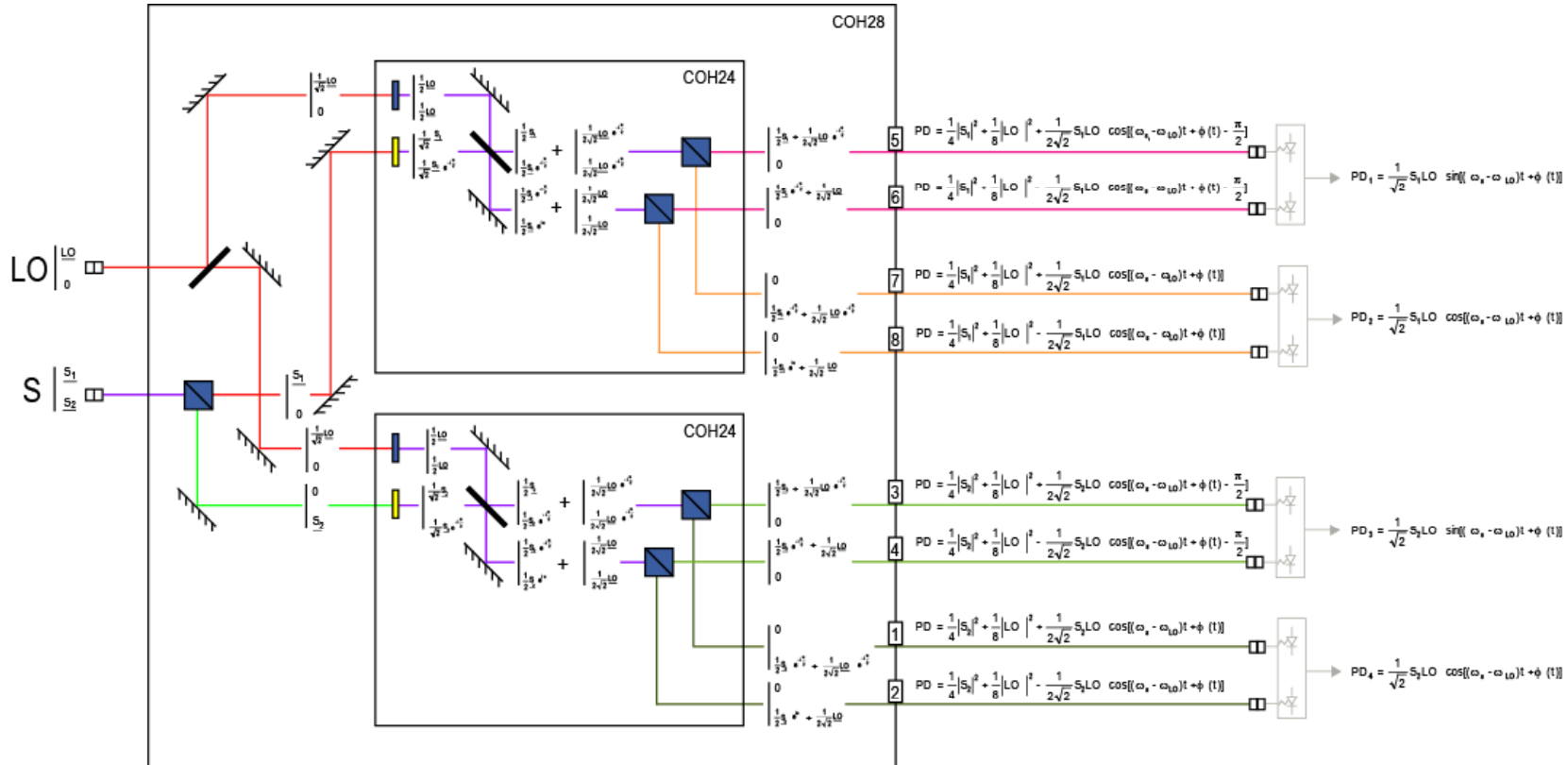



$$\underline{S}_1 = S_1 e^{i(\omega_s t + \phi(t))}$$

$$\underline{S}_2 = S_2 e^{i(\omega_s t + \phi(t))}$$

$$\underline{LO} = LO e^{i(\omega_{LO} t)}$$

 polarizing beam splitter

 half waveplate

 balanced photodiodes

 50/50 beam splitter

 quarter waveplate

Package and Fibres labelling

- COH28

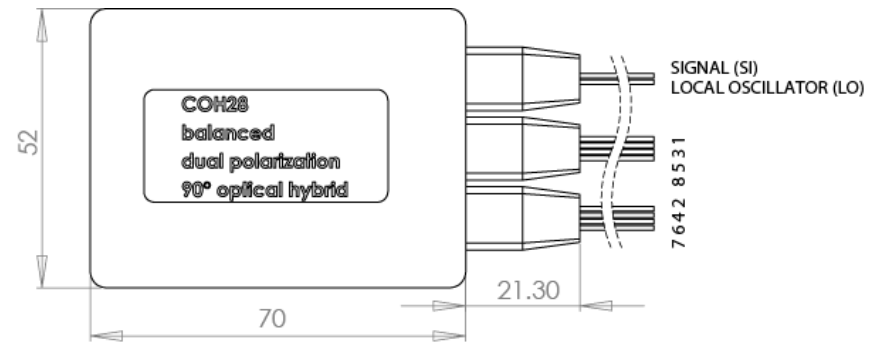

- COH24

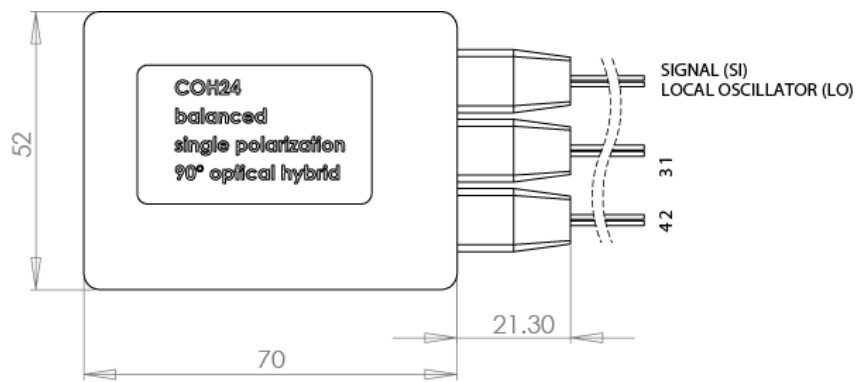

90° Phase shift vs T(°C)

+/-1° over -5°C – 80°C

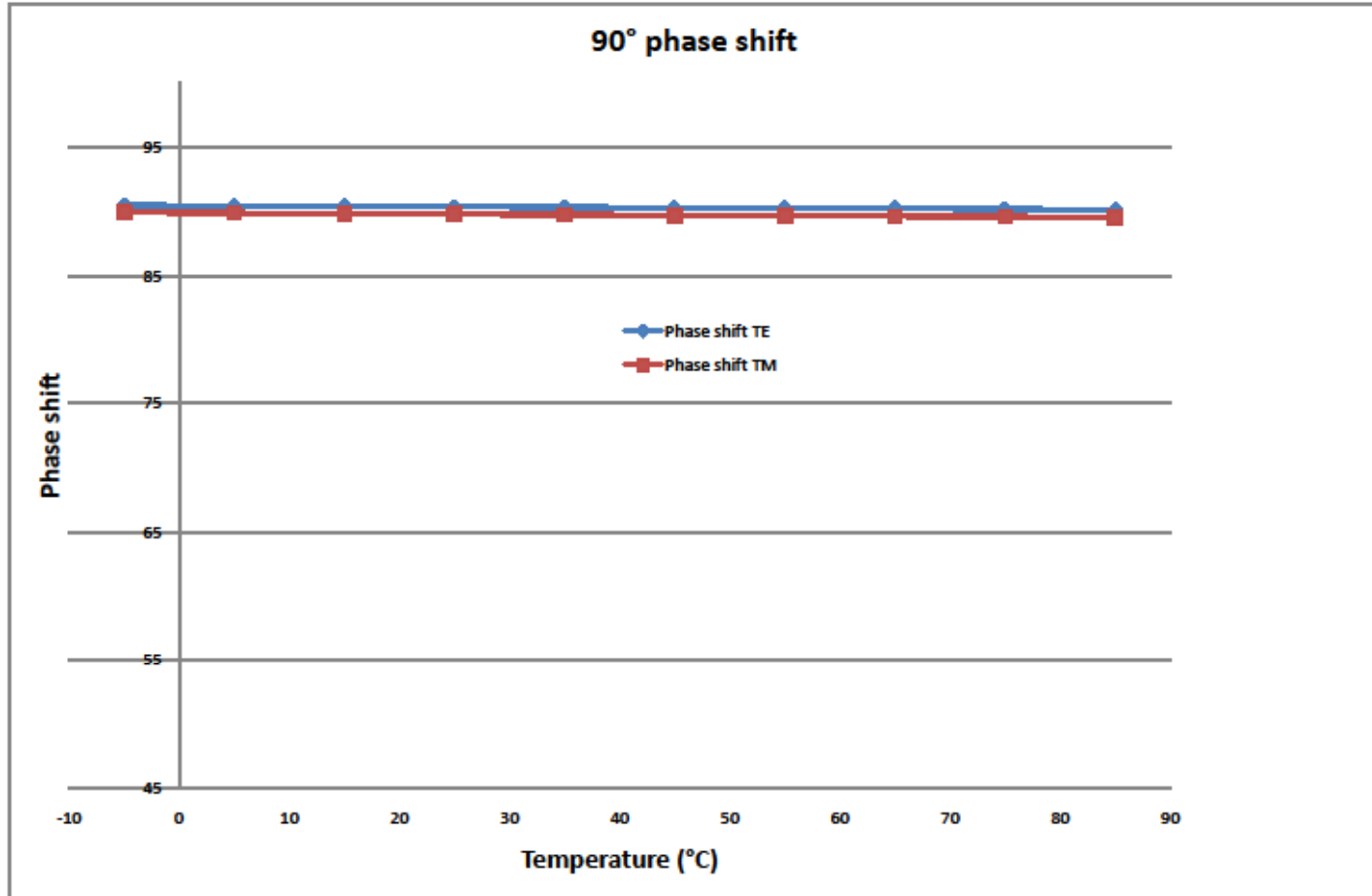

90° Phase shift vs Frequency

+/-2° over 191THz-197THz

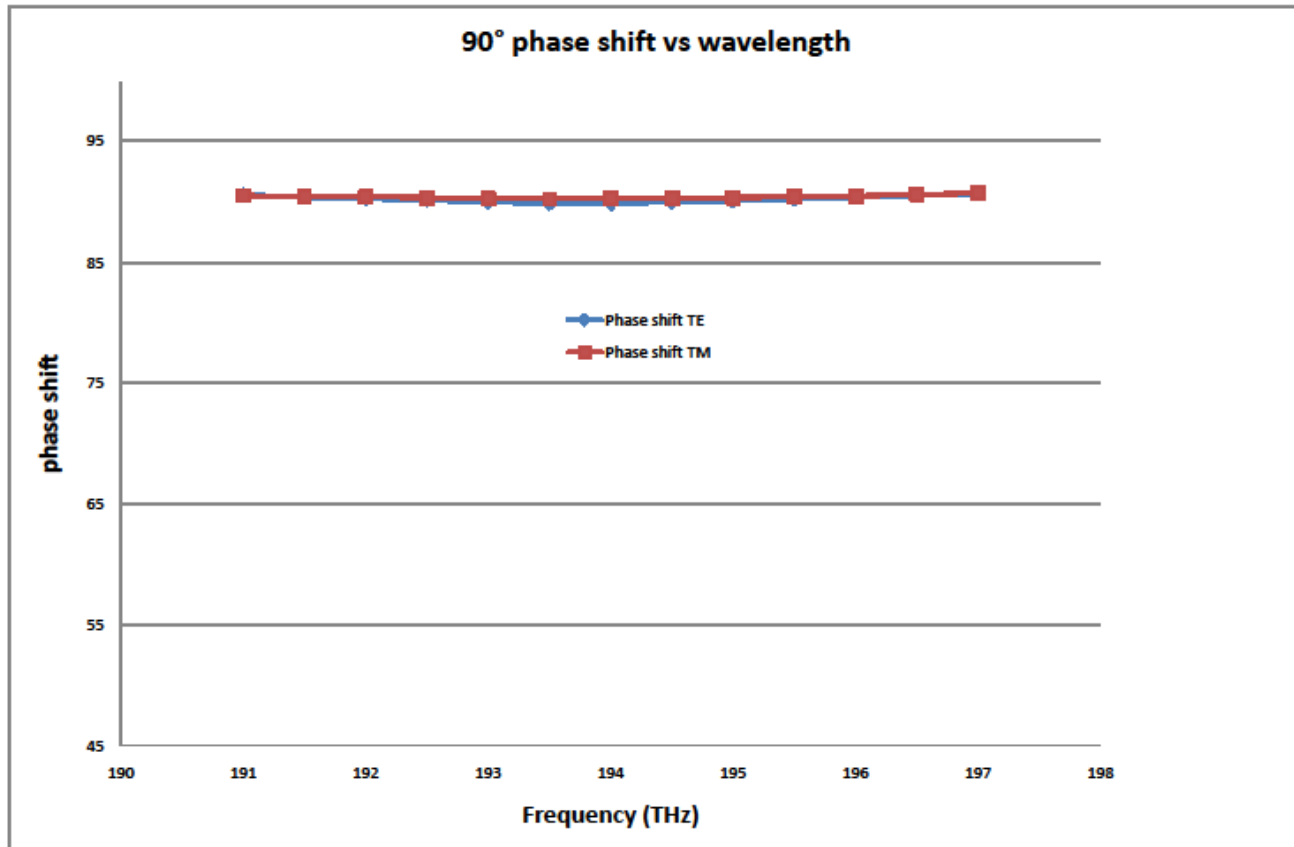

- Wavelength method
 - » homodyning the signal with itself delayed with a delay of T ,
 - » interferences with a FSR equals to $1/T$,
 - » Monitoring the outputs as a function of optical frequency->**curves are shifted of phase steps of 90°**
- Time based method
 - » Homodyning the signal with itself shifted with a frequency F
 - » Monitoring the outputs will show the phase shifts